



# SOLAR INDUSTRIAL LINE

USER'S GUIDE



# CONGRATULATIONS

on your purchase from Trojan Battery Company, the manufacturer of the world's most trusted deep-cycle batteries. The battery you purchased was engineered by Trojan to deliver superior power, performance, durability, and reliability for use in a broad range of demanding applications. Our goal is to provide reliable energy storage solutions that enhance the way people live and work around the world.

TROJAN BATTERY  
COMPANY WITH  
QUALITY SYSTEM  
CERTIFIED BY DNV  
= ISO 9001:2015 =

# THIS USER'S GUIDE

was created by Trojan's application engineers and contains vital information regarding proper care and maintenance of your new battery. Please read through this User's Guide carefully and completely before using your battery. It will help you achieve optimum performance and long life from your new investment.

If you have any questions concerning safety precautions or for any assistance in installing or using the batteries in your system, contact Trojan Battery Company's technical support engineers at one of the following numbers, or send us an email through our website at [www.trojanbattery.com/tech-support/](http://www.trojanbattery.com/tech-support/).

[www.trojanbattery.com](http://www.trojanbattery.com)



## **TECHNICAL SUPPORT**

800-423-6569 Ext. 3045 / +1-562-236-3045

[technical@trojanbattery.com](mailto:technical@trojanbattery.com)

# CONTENTS

<b>1</b>	<b>SAFETY .....</b>	<b>5</b>	<b>6</b>	<b>STORAGE.....</b>	<b>22</b>
<b>2</b>	<b>EQUIPMENT NEEDED .....</b>	<b>6</b>		6.1. Storage in Hot Environments .....	22
<b>3</b>	<b>BATTERY INSTALLATION.....</b>	<b>6</b>		6.2. Storage in Cold Environments.....	23
	3.1. Inspection .....	6	<b>7</b>	<b>MAXIMIZING THE PERFORMANCE</b>	
	3.2. Battery Connections.....	7		<b>OF YOUR TROJAN BATTERY.....</b>	<b>23</b>
	3.3. Terminal Types .....	7	<b>8</b>	<b>WHAT TO EXPECT FROM</b>	
	3.4. Correct Hardware Installation.....	8		<b>YOUR TROJAN BATTERY.....</b>	<b>24</b>
	3.5. Cable Size.....	10	<b>9</b>	<b>TROUBLESHOOTING .....</b>	<b>25</b>
	3.6. Torque Values.....	10		9.1. Preparation for Testing .....	25
	3.7. Terminal Protection.....	11		9.2. Voltage Testing while Charging .....	25
	3.8. Connecting Batteries in Banks .....	12		9.3. Specific Gravity (flooded/wet batteries only).....	26
	3.9. Ventilation.....	13		9.4. Open Circuit Voltage Testing.....	26
	3.10. Battery Orientation.....	13	<b>10</b>	<b>BATTERY RECYCLING .....</b>	<b>27</b>
	3.11. Battery Environment .....	13	<b>11</b>	<b>BATTERY ABBREVIATIONS.....</b>	<b>28</b>
	3.12. Temperature.....	14			
	3.13. Other Installation Considerations.....	14			
<b>4</b>	<b>PREVENTATIVE MAINTENANCE.....</b>	<b>15</b>			
	4.1. Inspection.....	15			
	4.2. Watering (flooded/wet batteries only).....	16			
	4.3. Cleaning .....	18			
<b>5</b>	<b>CHARGING &amp; EQUALIZING.....</b>	<b>18</b>			
	5.1. Initial Charge.....	18			
	5.2. Normal Charging .....	18			
	5.3. Equalizing (flooded/wet batteries only) .....	21			

# 1 SAFETY

Since batteries deliver large amounts of power that can cause injury and even death, observing safety rules is of paramount importance. For your safety and the safety of those around you, please observe the following checklist when working on or around batteries.

Always	Never
<b>Always charge batteries in well-ventilated areas</b>	<b>Never charge a flooded battery without securing vent caps on the cells</b>
Always wear protective clothing, gloves, and safety goggles	Never smoke near batteries
Always use insulated tools when working on batteries	Never wear jewelry or other metal objects when working on or around batteries
Always check connections for proper torque	Never make direct contact with the electrolyte (sulfuric acid). If this occurs, flush with large amounts of water.
Always keep sparks, flames, and metal objects away from batteries. This includes sources of static electricity.	Never place objects on top of batteries
Always use short cables of appropriate size to minimize voltage drop	Never add acid to a battery
Always ensure plates are covered in water before charging	Never charge a frozen battery
Always make sure charger is set for the appropriate battery type—SIND batteries are flooded batteries	Never charge a battery when the temperature is above 122°F (50°C)
Always charge batteries before installing	Never store batteries unless they are fully charged
Always neutralize small spills with baking soda and water. For large spills, contact the appropriate first responders.	Never leave an acid spill unattended
Always make sure chargers are off or disconnected while working on batteries	Never work on a grounded battery system without removing the source of ground. If you must work on a grounded system, ensure that proper procedures and Personal Protective Equipment (PPE) are used.
Always use lockout/tag-out procedures on large systems according to the appropriate code	Never dispose of lead acid batteries as household waste. Use recycling channels in accordance with local, state, and federal regulations
Always disconnect a battery in sections to reach safe working voltage levels if battery bank voltages exceed 48 VDC nominal.	Never connect or disconnect terminals from batteries without first disconnecting loads
Always keep flooded/wet batteries in an upright position	
Always use proper lifting techniques and/or material handling equipment when moving batteries.	

 **WARNING!** Risk of fire, explosion, or burns. Do not disassemble, heat above 158°F (70°C), or incinerate.

## 2 EQUIPMENT NEEDED

Before installation or maintenance of your batteries, have the following equipment available:

- › Proper Personal Protective Equipment (PPE) (eye protection, acid-resistant gloves, and appropriate footwear)
- › Distilled or deionized water
- › Insulated tools
- › Sodium Bicarbonate Solution: 1 cup of baking soda to 1 gallon of water (60 ml of baking soda per liter of water)
- › Terminal protectant (NO-OX-ID™ grease or a high-quality spray)
- › Voltmeter
- › Hydrometer
- › Battery charger

## 3 BATTERY INSTALLATION

To ensure you install your batteries properly and safely, please use the following guidelines.

### 3.1 INSPECTION

Check for visible damage including cracks, dents, deformation and other visible abnormalities. The tops of the batteries and terminal connections should be clean, free of dirt and corrosion, and dry. Any fluid on or around the battery could indicate that the case is not properly sealed or that the battery has been over-watered. Ensure that there is one cable per battery. Make sure the electrolyte level covers the plates, but be sure not to overfill the battery as the level of electrolyte will rise during the charging process.

If any problems are detected with the batteries, contact Trojan technical support or contact your battery distributor. If damage occurred in transit, contact your freight carrier.

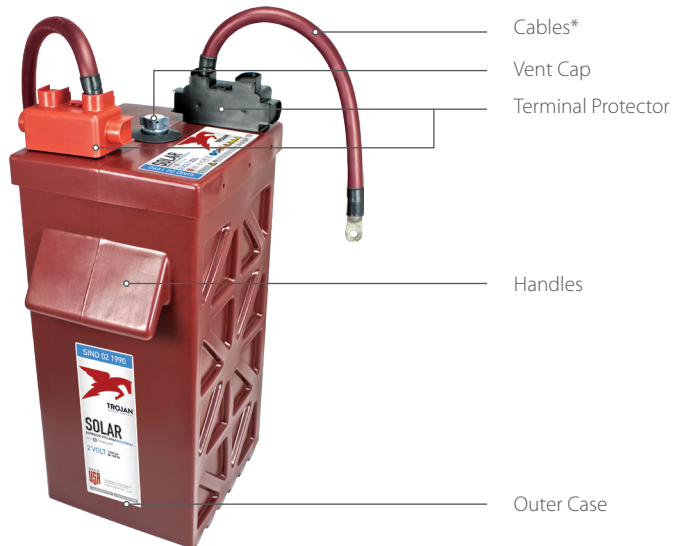

\*Trojan recommends using UL listed cables, such as Trojan's premium-quality maroon cables.

### 3.2 BATTERY CONNECTIONS

Battery cables provide the link between the batteries, equipment and charging system. Faulty connections can lead to poor performance, terminal damage, meltdown, or fire. To ensure proper connections, please use the following guidelines for cable size, torque values and terminal protection.

### 3.3 TERMINAL TYPES

Figure 1 illustrates the terminal found on Trojan Solar Industrial batteries. The appropriate dry torque for bolts through the terminal is 100-120 in-lb (11-14 Nm).

**FIGURE 1 – SOLAR INDUSTRIAL TERMINAL**

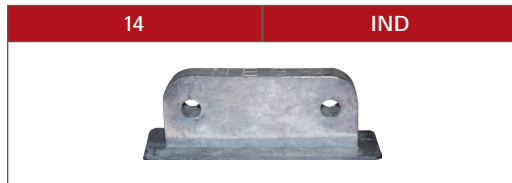

### 3.4. CORRECT HARDWARE INSTALLATION

When using flat washers, it is very important to ensure the battery cable lug is contacting the lead surface of the terminal, and the washer is placed on top of the lug. Do not place a washer between the battery terminal and the lug, as this will create high resistance and cause excessive heating of the connection and terminal. It is important that fasteners be tightened to the appropriate torque.

Each Trojan Solar Industrial battery is shipped with a hardware kit that contains 2 bolts, 4 flat washers, 2 lock washers, and 2 nuts. *Figure 2* illustrates the proper arrangement of components.

To properly connect the cable to the terminal, remove the terminal protectors as noted in the Terminal Protection Installation *Section 3.7* and follow the steps below.

**FIGURE 2 - SOLAR INDUSTRIAL TERMINAL CONFIGURATION**

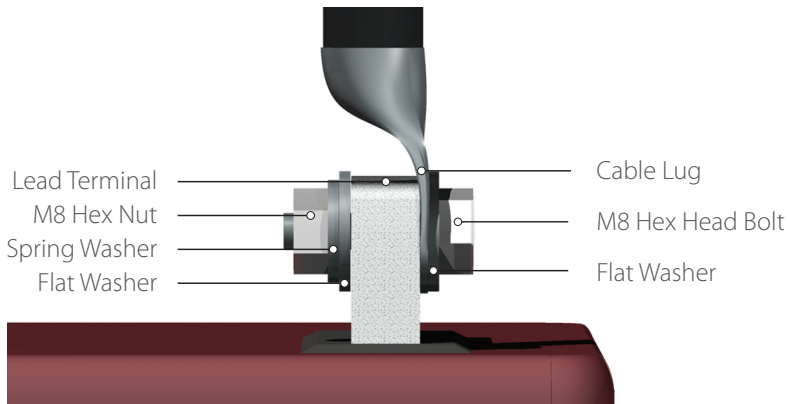

- ▶ Using a small piece of steel wool or a small wire brush, clean the surface of the lead terminal of the battery on the side the cable lug will be bolted to.
- ▶ Heat the container of No-OX-ID™ grease in hot water just to the point of thinning. Using a paintbrush, apply a light coat of the grease to the contact surface of the terminal.
- ▶ Place the flat side of the cable lug as illustrated above directly on the lead terminal of the battery.
- ▶ Place one of the stainless steel flat washers supplied on the stainless steel M8 hex head bolt against the inside head of the bolt.
- ▶ Place the hex head bolt with the installed washer through the cable lug and through one of the holes in the lead battery terminal.
- ▶ Place the second stainless steel flat washer on the end of the bolt protruding through the terminal and against the flat side of the lead battery terminal.



- Place the stainless steel split spring washer on the end of the bolt that is protruding through the terminal, against the flat washer.
- Install the hex stainless steel M8 nut on the bolt and tighten the nut with your fingers. Do not torque the bolts until all the cables are installed to allow some adjustment of position.
- After all connections are assembled, torque all stainless steel connector bolts to 100-120 in-lbs (11-14 Nm).
- Using a paintbrush, apply a light coat of the heated NO-OX-ID™ grease to the bolted connection, making certain to coat the cable lug, stainless steel bolt, washers and nut. Do not apply the NO-OX-ID™ grease to the cable insulation or the plastic parts of the battery.

### 3.5. CABLE SIZE

Battery cables should be sized to handle the expected load. Refer to *Table 1* for the maximum amperage based on the cable/wire gauge size. Note that Trojan Battery supplies a single maroon 4/0 cable with each Solar Industrial battery, which will be sufficient for all of the inter-battery connections.

**TABLE 1**

Cable/Wire Gauge Size, AWG (mm <sup>2</sup> )	Ampacity (amps)
14 (2.08)	20
12 (3.31)	25
10 (5.26)	35
8 (8.36)	50
6 (13.3)	65
4 (21.1)	85
2 (33.6)	115
1 (42.4)	130
1/0 (53.5)	150
2/0 (67.4)	175
4/0 (107)	230

Table values are from NEC Table 310.15(B)16 for copper cables rated at 75°C, operating at an ambient temperature of no more than 30°C. Lengths in excess of 6 feet (1829 mm) may require heavier gauge wire to avoid unacceptable voltage drop. In series/parallel battery banks, it is preferable for all series cables to be the same length, and all parallel cables to be the same length.

For more information refer to the National Electrical Code for correct cable/wire size, which can be located at [www.nfpa.org](http://www.nfpa.org).

### 3.6. TORQUE VALUES

Tighten all cable connections to 100-120 in-lb (11-14 Nm) to make sure there is good contact with the terminals. Over-tightening terminal connections can cause terminal breakage and loose connections can result in terminal meltdown or fire.

 **WARNING!** Use an insulated wrench when making battery connections.

### 3.7. TERMINAL PROTECTION

Trojan Solar Industrial batteries include terminal protectors for the purpose of keeping the terminals clean and dry in order to avoid corrosion and short-circuiting. Cable installation requires the removal of the terminal protectors which involves the following steps:

**FIGURE 3 - TERMINAL PROTECTOR**





- The protector has two locating pins that fit through the holes of the terminal.
- The protector is made of two parts that are held together with a simple latch that snaps through a locking clip.
- To remove the protector, simply squeeze the latch pins toward the center to clear the latch while pulling gently on each part. Do not use excessive force, as the part or latch could break.
- Once the cable connection is in position, determine which knockout to remove on the protector so the cover will slip over the cable end and the two parts of the protector will latch back together.
- There are four locations to choose to cover most installations. To remove the knockout, simply twist by hand or remove with pliers.
- Remove the locating pin in the large half of the protector where the cable goes through the terminal hole to allow the part to snap in place and back together. If the terminal has two cables connected to it, both pins should be removed and both knockouts should be used in the large half of the protector. The pin will snap off or can be cut off with snips. If dual cables are utilized, the protector will be held in place by the cables.
- Only service one protector and make one connection at a time to assure the battery is not shorted or inadvertently grounded.
- If the system is relocated, and the protector will not work with the new installation, replace with a new protector to assure the system is safe.

### 3.8. CONNECTING BATTERIES IN BANKS

You can increase capacity and voltage, or both, by configuring your batteries as shown in *Table 2*.

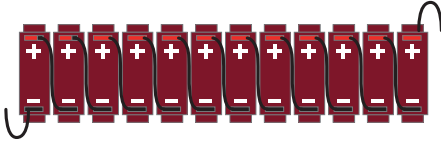
**TABLE 2**

SERIES CONNECTION	
	
To increase voltage, connect batteries in series. This will not increase the system capacity.	
EXAMPLE	Twelve SIND 02 2450 batteries connected in series
	System Voltage = $2V \times 12 = 24V$ System Capacity = 2450Ah ( $C_{100}$ )
PARALLEL CONNECTION	
	
To increase capacity, connect batteries in parallel. This will not increase the system voltage.	
EXAMPLE	Two SIND 02 2450 batteries connected in parallel
	System Voltage = 2V System Capacity = $2450Ah + 2450Ah = 4900Ah$ ( $C_{100}$ )

SERIES/PARALLEL CONNECTION	
	Note: maximum of three parallel strings without a Battery Management System
	To increase both voltage and capacity, connect additional batteries in series and parallel.
<b>EXAMPLE</b>	Twenty-four SIND 02 245, 2V batteries rated at 2450Ah Connected in Series/Parallel
	System Voltage $2V \times 12 = 24V$ System Capacity = $2450Ah + 2450Ah = 4900Ah (C_{100})$

### 3.9. VENTILATION

Deep-cycle flooded/wet lead acid batteries release small amounts of gas during usage, particularly during the charging process. **It is critical to charge batteries in a properly ventilated area.** For battery-specific information helpful in determining ventilation needs, please contact Trojan Battery Company's technical support engineers.

### 3.10. BATTERY ORIENTATION

Deep-cycle flooded/wet batteries **must be placed upright at all times.** Fluid in the battery will spill if the battery is placed on its side or at an angle.

Due to the dual container design of the Solar Industrial Line, Trojan recommends installing the batteries in a battery room, on a sealed concrete or brick floor. If the batteries are installed in a battery rack designed for the Solar Industrial line, the batteries should sit on the bottom of the rack and should not be suspended by the handles. Trojan does not provide battery racks. Please contact a qualified rack supplier to obtain appropriate racks.

### 3.11. BATTERY ENVIRONMENT

Batteries should be stored and used in a clean, cool and dry place, keeping water, oil, and dirt away from the batteries. If any of these materials are allowed to accumulate on the batteries, tracking and current leakage can occur, resulting in self-discharge and possible short-circuits. Battery chargers should also be installed in well-ventilated, clean areas that are easily accessible. Relative humidity should be <90%.

### **3.12. TEMPERATURE**

The recommended operating temperature range for Solar Industrial batteries is -4°F to 113°F (-20°C to +45°C). Note that battery life diminishes as temperature increases, while capacity increases with temperature.

It is important to minimize temperature variations between the cells. Therefore, avoid restricting airflow by tightly packing batteries together. The batteries should have a minimum of 1.00" (25.4 mm) of space between them to allow for adequate airflow.

### **3.13 OTHER INSTALLATION CONSIDERATIONS**

#### **3.13.1 SPACE**

Trojan recommends that the aisle space provided in front of the battery bank be a minimum of 36 inches (915 mm). The designer/installer must verify the requirements for aisle space in all applicable local codes or regulations. We recommend maintaining a minimum of 12 inches (305 mm) of free space above the tops of the battery terminal posts to permit access for maintenance or removal / replacement. Each battery should be accessible for the addition of distilled water and for taking voltage and hydrometer readings.

#### **3.13.2 CODES**

Building and fire codes may require special monitoring, unique electrical installation requirements and switch gear, fire protection and spill containment systems for battery installations. Please consult local building and fire codes.

#### **3.13.3 FLOOR**

Batteries should be kept on a level surface. Sealed concrete, epoxy-coated concrete or membrane installed acid brick system capable of supporting the weight of the battery system and any associated equipment is preferable. Shim up to 1/4 inch per foot (6 mm per 305 mm) maximum to level battery rack or cabinet or shelving front to rear and side to side.

#### **3.13.4 ANCHORING**

Anchoring and isolation devices should meet all local, state and country codes, and all industry standards. Floor anchoring, seismic requirements and equipment/ specifications and its design are the responsibility of the system designer/installer.

# 4 PREVENTIVE MAINTENANCE

## 4.1. INSPECTION

The following procedures define the recommended schedule for proper maintenance and record keeping. Readings should be taken when the batteries are at full state of charge and not under load (open-circuit). The Trojan Solar Industrial warranty requires that records be kept on the Battery Maintenance Log Sheet (included in this Guide) and is available for download on our website at <https://www.trojanbattery.com/literature>. Wear protective rubber gloves, rubber boots and eye protection at all times when working on batteries.

### INSPECT MONTHLY

- Review general appearance and cleanliness of the batteries and battery area.
- Check electrolyte levels by removing vent caps and looking into vent wells.
- Look for evidence of electrolyte leaks on the ground.
- Check for cracks in cases or leakage of electrolyte.
- Review terminals and connectors for corrosion. Clean with a sodium bicarbonate/water solution if needed (see below).
- Record ambient temperature so there is a record of the temperature history.
- Review the condition of ventilation equipment.
- Measure each battery voltage using a voltmeter.
- Measure the specific gravity of each cell using a hydrometer and electrolyte temperature with a hydrometer and a thermometer.
- Check charge controller or inverter/charger settings for manufacturer recommendations.

All of this information should be recorded on the battery maintenance log sheet and should be kept for the duration of the life of the battery.

### INSPECT ANNUALLY

In addition to the monthly items, perform the following checks on an annual basis:

- Check all bolted connections to see if tightening is required. Ensure that all bolts are within the recommended torque range of 100-120 in-lbs (11-14 Nm).
- Check the integrity of the rack, stand, battery tray, or other accessories as needed.
- Check the area around the battery to ensure that nothing can fall on or short the battery string.

This data will be required for any warranty claim made on the battery. For battery bank protection and to suit local conditions/requirements, more frequent readings may be necessary or required.

## 4.2. WATERING (FLOODED/WET BATTERIES ONLY)

Deep-cycle flooded/wet batteries need to be watered periodically. The frequency depends on battery usage, charging and operating temperature. Check new batteries every few weeks to determine the watering frequency for your application. It is normal for batteries to need more watering as they age.

- ▶ Use only distilled or deionized water. Tap water can contain contaminants that will damage the battery. Also, be aware that water can pick up impurities from containers, piping, and fixtures. Do not use metal containers to store water. Use a clean container made of glass, rubber, or plastic that has not been used to store anything other than water in the past. *Table 3* contains the limits for impurities to avoid damaging batteries.
- ▶ Fully charge the batteries prior to adding water. Only add water to discharged or partially charged batteries if the plates are exposed. In this case, add just enough water to cover the plates and then charge the batteries. Once completed, continue with the watering procedure below.
- ▶ Check the electrolyte levels by removing the vent caps and placing them upside down so that dirt does not accumulate on the underside of the cap.
- ▶ If the electrolyte level is barely covering the plates, add distilled or deionized water until the water reaches 1/8" (3 mm) below the bottom of the vent well (Figure 5).

**FIGURE 5**

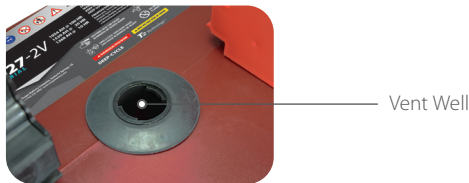

- ▶ After adding water, secure vent caps back onto batteries.
- ▶ Water should only be added to batteries when the battery temperature is above 45°F (7°C).
- ▶ If you have purchased a single-point watering system from Trojan Battery, please refer to the associated User's Guide available at [www.trojanbattery.com](http://www.trojanbattery.com).



**TABLE 3**

WATER IMPURITY LIMITS		
Impurity	Parts Per Million	Effects of Impurity
Color	Clear and "White"	-
Suspended Matter	Trace	-
Total Solids	100	-
Organic and Volatile Matter	50	Corrosion of positive plate
Ammonia	8.0	Slight self-discharge of both plates
Antimony	5.0	Increased self-discharge, reduces life, lower on-charge voltage
Arsenic	0.5	Self-discharge, can form poisonous gas at negative plate
Calcium	40	Increase of positive plate shedding
Chloride	5.0	Loss of capacity in both plates, greater loss on the positive plate
Copper	5.0	Increased self-discharge, lower on-charge voltage
Iron	3.0	Increased self-discharge at both plates, lower on-charge voltage
Magnesium	40	Reduced life
Nickel	None Allowed	Substantial lowering of on-charge voltage
Nitrates	10	Increased sulfation on the negative plate
Nitrites	5.0	Corrosion of both plates, loss of capacity, reduced life
Platinum	None Allowed	Increased self-discharge, lower on-charge voltage
Selenium	2.0	Positive plate shedding
Zinc	4.0	Slight self-discharge of negative plate

### 4.3. CLEANING

Check the battery for cleanliness at regular intervals and keep terminals and connectors free of corrosion. Terminal corrosion may adversely affect the performance of the battery and present a safety hazard.

- Disconnect the battery from the charging source and the load.
- Check that all vent caps are secured properly on the battery.
- Wipe off any accumulation of dust from the cell covers with a cloth dampened with clean water.
- Clean the top of the battery, terminals, and connections with a cloth or non-metallic brush and a solution of baking soda and water comprised of 1 cup of baking soda to 1 gallon of water (60 ml of baking soda per liter of water). **Do not allow cleaning solution to get inside the battery.**
  - In cases where heavy corrosion is present on the terminals or connectors, unbolt and remove all connectors, clean the cell posts and connectors with the sodium bicarbonate solution. Clean contact surfaces by rubbing with a non-metallic stiff bristle brush or non-metallic scouring pad. Do not remove the plating from the connectors. If copper is exposed on the connectors, replace the cables. Reassemble the system as instructed in *Section 3*.
- Rinse with water and dry with a clean cloth.
- Reapply a thin coat of NO-OX-ID™ to all connections.
- Keep the area around batteries clean and dry.

## 5 CHARGING & EQUALIZING

### 5.1. INITIAL CHARGING

Due to the potential for self-discharge during shipping and storage, batteries should be given a full charge prior to first use. See the next section for details on proper charging.

### 5.2. NORMAL CHARGING

Proper charging is imperative to maximize battery performance. Both under- or over-charging can significantly reduce the life of the battery. For proper charging, refer to the instructions that came with your charge controller and/or inverter/charger. Most charge controllers and inverter/chargers are automatic and pre-programmed, but they may allow the user to set the voltage and current values manually.

- **Charge only in well-ventilated areas.**
- Check each battery cell's electrolyte level to make sure the plates are covered with electrolyte before charging.
- Check that all vent caps are secured properly on the battery before charging.
- Before charging, make sure the charging device is set to the appropriate program for deep cycle flooded/wet batteries.

- Charging time will vary depending on battery size, charging device output, and depth of discharge.
- Lead-acid batteries do not have a memory effect and should not be fully discharged prior to charging. Do not discharge your battery more than 80%. This safety factor will eliminate the chance of over-discharging and damaging your battery. Renewable energy applications are typically designed for a 20% - 50% depth of discharge.
- Temperature compensated charging is desirable if the charging device has the capability to do so. Temperature compensation coefficients raise the voltage/cell for temperatures below 77°F (25°C), and lower the voltage/cell for temperatures above 77°F (25°C).
- Never charge a frozen battery.
- Avoid charging at temperatures above 113°F (45°C).

Trojan recommends a 3-phase I-V-I profile for charging its flooded batteries

- Phase 1: Constant current bulk charge
  - A constant current equal to 10-13% of C20 is applied as the voltage slowly increases. The bulk phase ends when the voltage rises to the absorption voltage.
- Phase 2: Constant voltage absorption charge
  - A constant voltage equal to 2.35-2.45 V/cell is applied as the current slowly declines. The absorption phase ends when the current falls to the finish current.
- Phase 3: Constant current finish charge
  - A constant current equal to 1-3% of C20 is applied as the voltage increases. The finish phase ends when the battery is fully charged. **Flooded batteries will gas (bubble) toward the end of the finish phase to ensure proper mixing of electrolyte.**

Refer to *Table 4* and *Figure 6* for system charging parameters and typical voltage and current profiles.

In applications where batteries are infrequently used, it is desirable to compensate for self-discharge by keeping a low charging voltage on the batteries. This is called the float voltage. Avoid using continuous float charging on flooded batteries that are charged more than once/week. When float charging is used, it is started immediately after the end of the finish stage. Following charge completion, add water if required as directed in *Section 4.2*.

**TABLE 4**

FLOODED/WET BATTERIES - NORMAL CHARGING PARAMETERS @ 25°C (77°F)							
Trojan Battery Line	Maximum Charge Current* (% of C <sub>20</sub> )	Absorption Voltage** (V/cell)	Maximum Absorption Phase Time (hours)	Finish Current (% of C <sub>20</sub> )	Equalization Voltage (V/cell)	Float Voltage (V/cell)	Temperature Compensation (V/cell)
Solar Premium and Signature	13%	2.40	4	1-3%	2.70	2.25	Fahrenheit: -2.8 mV x (T <sub>battery</sub> -77)  Celsius: -5 mV x (T <sub>battery</sub> -25)

\*If charging time is limited contact Trojan Technical Support for assistance.

\*\*In cases where the charger has a bulk voltage setting rather than a current, use the above absorption settings.

**FIGURE 6**

**RECOMMENDED DEEP-CYCLE FLOODED/WET CHARGING PROFILE**

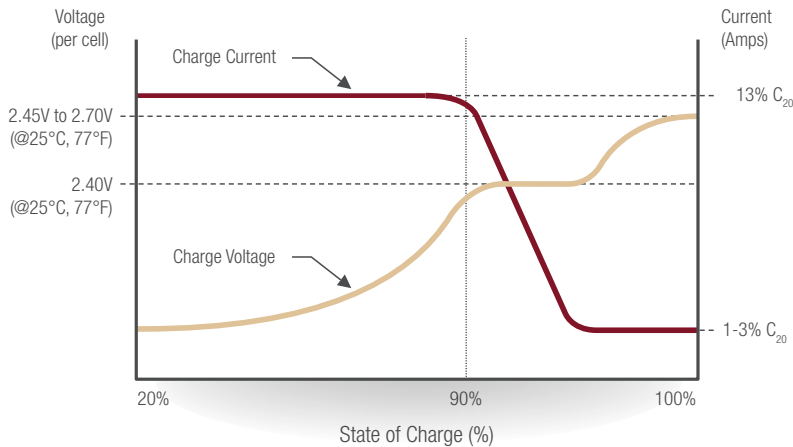

Note: Charging time will vary depending on battery size, charger output, and depth of discharge.

### 5.3. EQUALIZING

- When batteries are used in a battery bank, over time some of the batteries can drift to a lower state of charge than others. This charge imbalance can lead to sulfation and premature battery failure. To correct these charge imbalances a process called “equalization” is used. Equalizing is an overcharge at the voltage specified in *Table 4* and is performed after fully charging deep-cycle flooded/wet batteries. An equalizing charge prevents electrolyte stratification and reduces sulfation, which are leading causes of battery failure. Trojan recommends equalizing for 2-4 hours in the following situations:
  - Periodically (every 30 days).
  - When batteries have a low specific gravity after charging ( $<1.230$ ).
  - When the range of specific gravities between cells is  $> 0.030$  points. Reference *Section 9.3* for instructions on specific gravity measurement.

Equalization can be performed either automatically (as programmed on the charge controller or inverter/charger) or by following the procedure below:

- Check the battery's electrolyte level in each cell to make sure the plates are covered before charging.
- Check that all vent caps are secured properly on the battery before charging.
- Set the charging device to equalizing mode. Note that the batteries will gas (bubble) during the equalization process.

Note: For a stand-alone photovoltaic (PV) system, an equalization charge can only be done when there is enough sun to fully charge the batteries, which may not occur daily.

- Measure the specific gravity every 30 minutes. Discontinue the equalization charge when the specific gravity no longer rises. The length of time to equalize a battery bank depends on the size of the system, the power source, and the system components.

## 6 STORAGE

The following tips will help ensure that your batteries emerge from storage in good condition:

- Charge batteries before placing them in storage.
- Store in a cool and dry location, protected from the elements.
- Disconnect from equipment to eliminate potential parasitic loads that may discharge the batteries.
- Batteries gradually self-discharge during transit and storage, so monitor the specific gravity or open-circuit voltage every 4 - 6 weeks.
- Batteries in storage should be charged when they decline to 70% SOC.
- Refer to *Table 5* for the relationship between SOC, specific gravity and open-circuit voltage. If charging is needed, follow the normal charging procedure outlined in *Section 5.2*.
- When batteries are taken out of storage they should be given an initial charge as outlined in *Section 5* prior to use.

**TABLE 5**

FLOODED/WET STATE OF CHARGE AS A FUNCTION OF SPECIFIC GRAVITY AND OPEN-CIRCUIT VOLTAGE					
STATE OF CHARGE (%)	SPECIFIC GRAVITY	CELL	12 VOLT	24 VOLT	48 VOLT
100	1.260	2.11	12.66	25.32	50.64
90	1.246	2.09	12.54	25.08	50.16
80	1.227	2.07	12.42	24.84	49.68
70	1.207	2.05	12.30	24.60	49.20
60	1.187	2.03	12.18	24.36	48.72
50	1.165	2.01	12.06	24.12	48.24
40	1.142	1.99	11.94	23.88	47.76
30	1.119	1.96	11.76	23.52	47.04
20	1.096	1.94	11.64	23.28	46.56
10	1.072	1.92	11.52	23.04	46.08

### 6.1. STORAGE IN HOT ENVIRONMENTS

Storage in hot environments (greater than 90°F or 32°C) can negatively impact batteries. Avoid direct exposure to heat sources, if possible, during storage. Batteries self-discharge faster at high temperatures. If batteries are stored during hot summer months, monitor State-of-Charge by checking specific gravity or open-circuit voltage every 2 - 4 weeks.

## 6.2. STORAGE IN COLD ENVIRONMENTS

If possible, avoid locations where freezing temperatures are expected during storage. Batteries can freeze in cold temperatures (less than 32°F or 0°C) if they are not fully charged. If batteries are stored during cold winter months, it is critical that they be kept at a high state of charge as outlined above.

Freezing Point of Electrolyte		
Specific Gravity	Temperature	
	°C	°F
1.280	-68.9	-92.0
1.265	-57.4	-71.3
1.250	-52.2	-62.0
1.200	-26.7	-16.0
1.150	-15.0	-5.0
1.100	-7.2	19

Source: BCI Service Manual © 1995

# 7 MAXIMIZING THE PERFORMANCE OF YOUR TROJAN BATTERY

- ▶ Follow all the procedures in this User's Guide for proper installation, maintenance and storage.
- ▶ Do not discharge your battery to more than 80% depth of discharge. This safety factor will eliminate the chance of over-discharging and damaging your battery.
- ▶ If you have any questions or concerns about battery care, please contact Trojan Battery Company's technical support engineers at 800-423-6569 Ext. 3045 or +1-562-236-3045 before a problem develops.

# 8 WHAT TO EXPECT FROM YOUR TROJAN BATTERY

- ▶ A new deep-cycle battery will not immediately deliver its full rated capacity. This is normal and should be expected since it takes time for a deep-cycle battery to reach peak capacity.
- ▶ Trojan's deep-cycle flooded batteries take 50 - 100 cycles to achieve full, peak capacity.
- ▶ When operating batteries at temperatures below 80°F (27°C), they will deliver less than the rated capacity. For example at 0°F (-18°C) the battery will deliver 50% of its capacity and at 80°F (27°C) it will deliver 100% of its capacity.
- ▶ When operating batteries at temperatures above 80°F (27°C), they will deliver more than the rated capacity but battery life will be reduced.
- ▶ The life of a battery is difficult to predict and will vary by application, frequency of usage and level of maintenance.

FIGURE 7

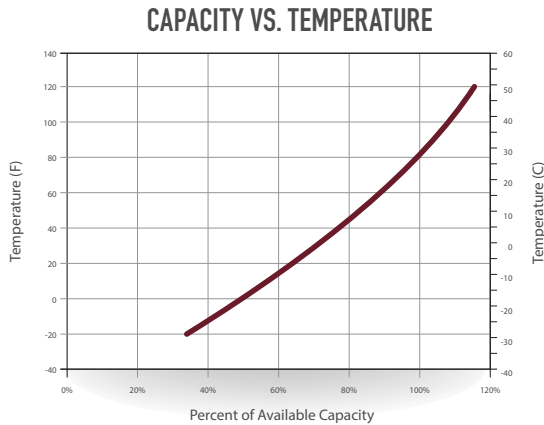

Note: Typical behavior at 5-Hr rate

FIGURE 8

### TYPICAL CYCLE LIFE OF A TROJAN SOLAR INDUSTRIAL BATTERY IN A STATIONARY APPLICATION

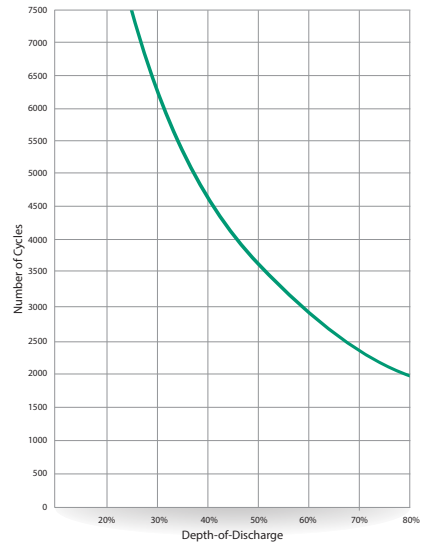



## 9 TROUBLESHOOTING

These battery testing procedures are guidelines only for identifying a deep-cycle battery that may need to be replaced. Unique situations may be observed that are not identified within this procedure. Please contact Trojan Battery Company's technical support engineers at 800-423-6569 Ext. 3045 or +1-562-236-3045 for help interpreting any test data. Please note that the Battery Maintenance Log Sheet with regularly recorded specific gravity and voltage readings must be provided for all warranty claims.

### 9.1. PREPARATION FOR TESTING

- ▶ Use appropriate Personal Protective Equipment (rubber gloves, goggles, apron, and rubber boots).
- ▶ Check that all vent caps are secured properly on the battery.
- ▶ Clean the top of the battery, terminals and connections with a cloth or brush and a solution of baking soda and water [1 cup of baking soda to 1 gallon of water (60 ml of baking soda per liter of water)]. Do not allow cleaning solution to get inside the battery. Rinse with water and dry with a clean cloth.
- ▶ Check battery cables and connections. Replace any damaged cables. Tighten any loose connections with an insulated wrench. Use the proper torque as described in *Section 3.3*.
- ▶ Check the electrolyte level and add water if necessary. Refer to Watering *Section 4.2*.

### 9.2. VOLTAGE TESTING WHILE CHARGING

- ▶ If needed, manually restart the charge controller or inverter/charger.
- ▶ While the batteries are charging, record the current in the last ½ hour of the charge cycle (if possible), and measure the battery bank voltage.
- ▶ If the current at the end of the charge is below 5 amps, and the battery set voltage is above the readings shown in *Table 6*, proceed to the step below to measure the on-charge voltages.

TABLE 6

MINIMUM VOLTAGE FOR ON-CHARGE TESTING						
SYSTEM/BATTERY VOLTAGE	48V	36V	24V	12V	8V	6V
END-OF-CHARGE THRESHOLD VOLTAGE	56V	42V	28V	14V	9.3V	7V

- ▶ If the end-of-charge voltage does not exceed these values, check the charger for proper output and equalize the batteries. If the set voltages are still low, you may have a failed battery.
- ▶ While the batteries are on-charge, measure the individual battery voltages.
- ▶ Record data on the Battery Maintenance Log Sheet for warranty purposes.
- ▶ Compare each voltage to the proper entry in *Table 7*. If any battery is below the appropriate Minimum Voltage Threshold and the variation between all of the voltages is greater than the Allowable Variation, the low battery may have failed.

**TABLE 7**

ON-CHARGE TEST THRESHOLDS		
NOMINAL BATTERY VOLTAGE	MINIMUM VOLTAGE THRESHOLD	ALLOWABLE VARIATION WITHIN A SET
2V	2.33V	0.33V
4V	4.66V	0.47V
6V	7.00V	0.7V

### 9.3. SPECIFIC GRAVITY (FLOODED/WET BATTERIES ONLY)

A specific gravity reading is the most accurate way to determine a battery's state of charge. This measurement is based on the density of the electrolyte compared to the density of water and is typically determined by the use of a hydrometer. The specific gravity of water is 1.000 and the specific gravity of the sulfuric acid electrolyte in a typically fully charged Solar Industrial battery is 1.260. Specific gravity measurements are used to determine if the battery is fully charged or if the battery has a weak or a bad cell. A high specific gravity means a higher density of acid to water, which normally indicates a higher state of charge. Specific gravity should be measured when the battery is not under a load and should not be measured soon after water is added to the battery. Wear eye protection, rubber gloves and have sodium bicarbonate solution and water on hand in case of acid spills.

- Use a reliable, high-quality hydrometer for specific gravity measurements.
- Fill and drain the hydrometer 2 - 3 times before drawing a sample from each cell.
- Measure specific gravity readings for all battery cells and record the data in the Battery Maintenance Log Sheet.
  - Correct specific gravity readings for temperature by adding 0.004 for every 10°F (5°C) above 80°F (27°C), and subtract 0.004 for every 10°F (5°C) below 80°F (27°C).
  - If every cell in the battery set is below 1.230, the batteries may be undercharged and require recharging.
  - If any battery has a specific gravity variation of more than 0.030 between cells, equalize the set.
  - If there is still a significant variation, there may be a failed battery.
- After testing, rinse the hydrometer out with fresh water at least five times to flush the acid out.

### 9.4. OPEN CIRCUIT VOLTAGE TESTING

Open circuit voltage testing is used to determine the battery's state of charge, however it is not as accurate as a specific gravity test, which measures each battery cell. The test is done when the load is disconnected from the battery.

For accurate voltage readings, batteries must remain idle at least 6 hours, and preferably up to 24 hours. Measure and record the individual battery voltages in the Battery Maintenance Log Sheet. If any recorded voltage differs from another one by more than 0.3V, equalize the set. Refer to *Section 5.3*, Equalizing.

Measure the individual battery voltages again. If any recorded voltage differs from another one by more than 0.3V, compared to any other battery in the set, you may have a failed battery.

# 10 BATTERY RECYCLING

Lead acid batteries are the environmental success story of our time. Per the International Lead Association, in Europe and the USA, 99% of all battery lead is recycled. In fact, lead acid batteries top the list as the most highly recycled consumer products. Trojan Battery supports proper recycling of your battery to keep the environment clean.

Please contact your nearest Trojan Distributor, at [www.trojanbattery.com](http://www.trojanbattery.com), to learn how to properly recycle your batteries.

Below is the process in which your Trojan battery will be recycled:

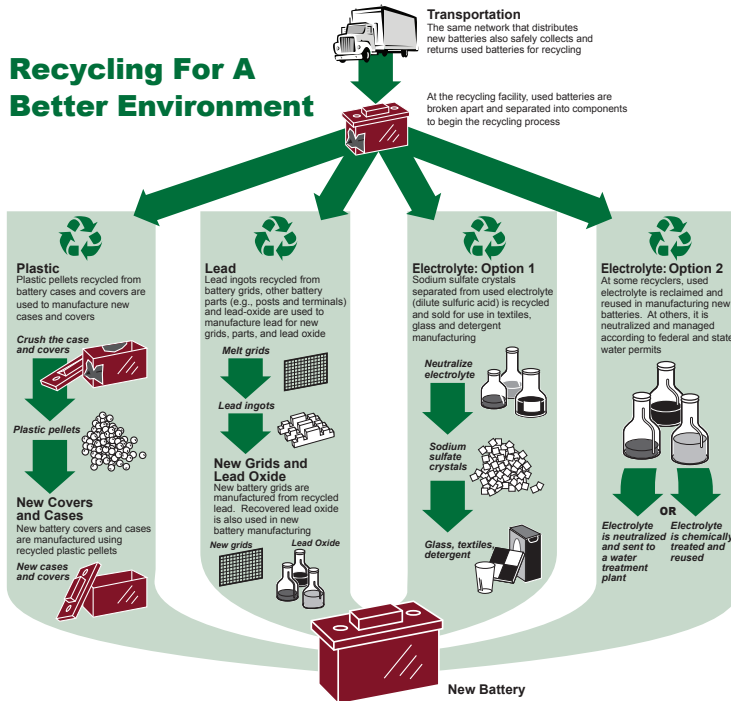

# 11 BATTERY ABBREVIATIONS

<b>A</b>	Ampere	<b>°F</b>	Degrees Fahrenheit
<b>Ah</b>	Ampere-hour	<b>IND</b>	Industrial Terminal
<b>AWG</b>	American Wire Gauge	<b>SOC</b>	State of Charge
<b>°C</b>	Degrees Celsius	<b>V</b>	Volt
<b>DOD</b>	Depth of Discharge		







# TROJAN BATTERY COMPANY

would like to thank you for selecting our battery. With close to 100 years of experience, Trojan Battery is the world's most trusted name in deep-cycle battery technology backed by our outstanding technical support. We look forward to serving your battery needs.

## TROJAN BATTERY COMPANY

12380 Clark Street, Santa Fe Springs, CA 90670 USA

Call **800-423-6569 Ext. 3045** or **+1-562-236-3045**  
or visit **[www.trojanbattery.com](http://www.trojanbattery.com)**



This publication is protected by copyright and all rights are reserved. No part of it may be reproduced or transmitted by any means or in any form, without prior consent in writing from Trojan Battery Company, LLC.

Trojan Battery Company and the Trojan Battery logo are registered trademarks of Trojan Battery Company.

T2 Technology, Maxguard T2 Separator, Alpha Plus Paste, HydroLink, Plus Series, Polyon, Smart Carbon™ and OverDrive AGM 31 are either registered trademarks or trademarks of Trojan Battery Company.

© 2020 Trojan Battery Company, LLC. All rights reserved. Trojan Battery Company is not liable for direct, indirect, special, exemplary, incidental or consequential damages that may result from any information provided in or omitted from this manual, under any circumstances. Trojan Battery Company reserves the right to make adjustments to this manual at any time, without notice or obligation.

